

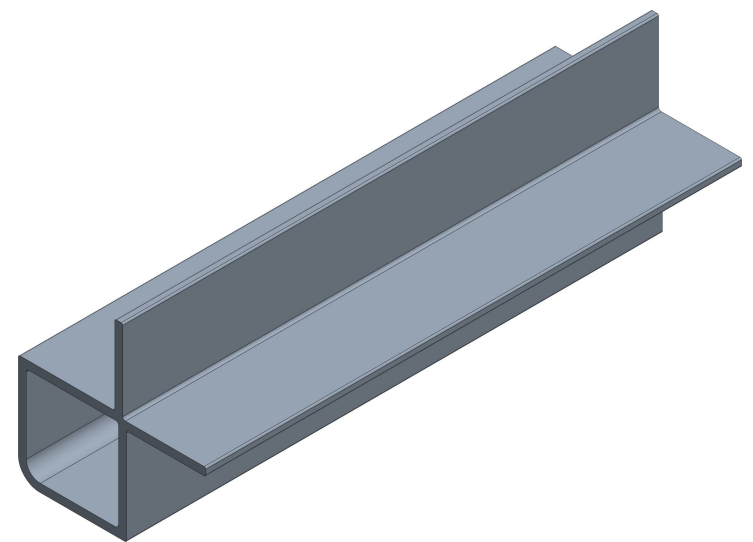

NOTE		
SL. NO.	NOTE	DESCRIPTION
1	<input type="checkbox"/>	INDICATES INSPECTION DIMENSION

REVISION HISTORY			
REV	DESCRIPTION	DATE	APPROVE

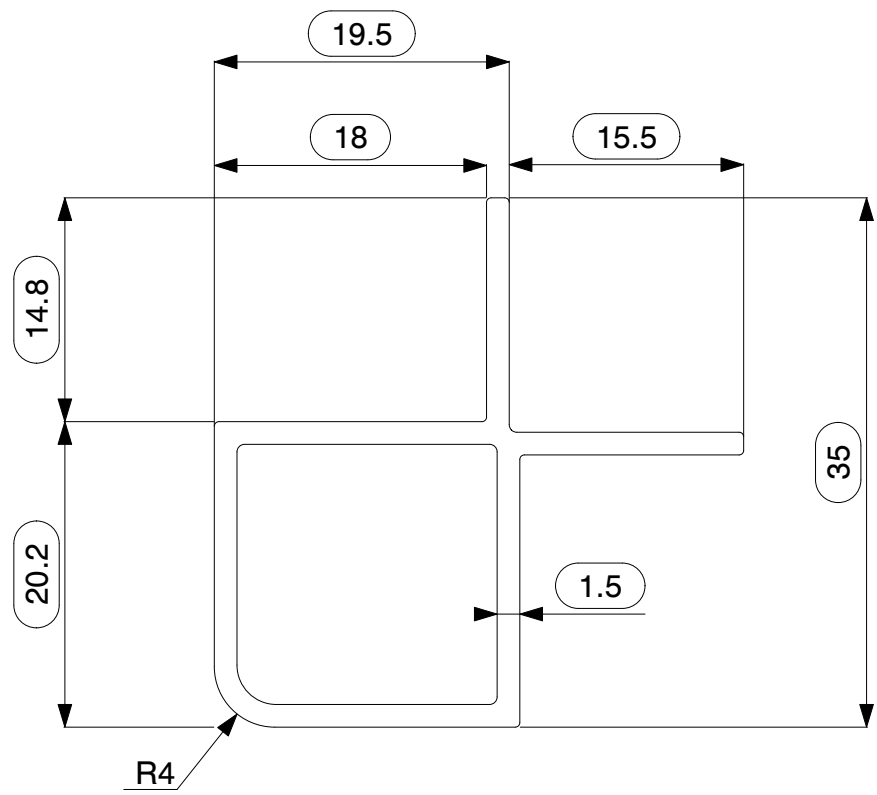

TOLERANCE #		APPROVALS		DATE
0.5 ~ < 10	±0.30	DRAWN	VISWA	28-01-2026
10 ~ < 25	±0.50	CHECKED	KALEEL	29-01-2026
25 ~ < 50	±0.70	APPROVED		
50 ~ < 100	±1.00	MATERIAL: EN AW 6063 - T6		
100 ~ < 150	±1.20	FINISH : MILL (Unless specified) Based on customer request on finish, below is applicable FOR ANODIZED : 5-10 MICRONS FOR POWDER COATED : 60-100 MICRONS		
THE MAXIMUM ALLOWABLE DEVIATION FOR ANY ANGLE IS ± 2°		PERIMETER: Ext : 137.03 mm Int : 67.04 mm	AREA: 154.26 mm ²	
TWIST ALONG THE LENGTH = 3 mm/M				
STRAIGHTNESS = 5 mm/M				
FLATNESS : 0.008 X WIDTH		CUT LENGTH: 6000 (±10) mm		
SCALE : 1:1		WEIGHT RANGE : 0.398 - 0.428 Kg/m		
CORNER & FILLET RADII : < 5 - ±0.5mm > 5 - ± 10%		ALL DIMENSIONS ARE IN mm (MILLIMETERS) UNTILL UNLESS SPECIFIED		



VIVANT
SOLUTIONS

VIVANT SOLUTIONS PRIVATE LIMITED,
PLOT NO: 329, SIDCO THIRUMULLAIVOYAL,
CHENNAI, TAMILNADU, INDIA

TITLE : NON THERMAL BREAK CORNER PROFILE FOR 20-15 SYSTEM

PART CODE : NTBLC-2015

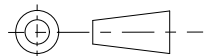
THIRD ANGLE PROJECTION	SIZE : A4
	RIBS : B = -

REFERENCE STANDARDS - BSEN-755-9-2008

REV : 0

1
2
3
4
5
6

1
2
3
4
5
6

A B C D E F G H I

NOTE		
SL. NO.	NOTE	DESCRIPTION
1	□	INDICATES INSPECTION DIMENSION

REVISION HISTORY			
REV	DESCRIPTION	DATE	APPROVE

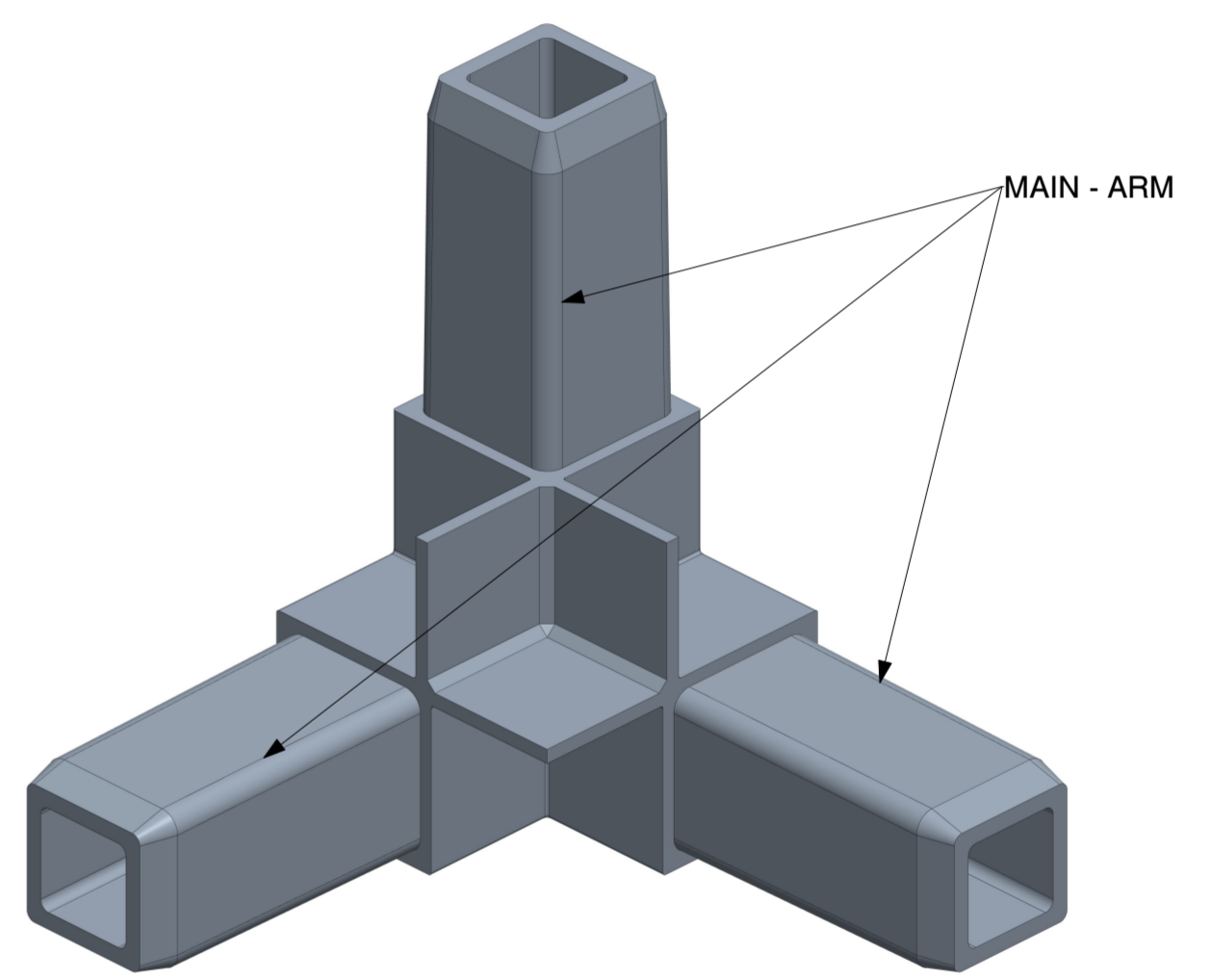
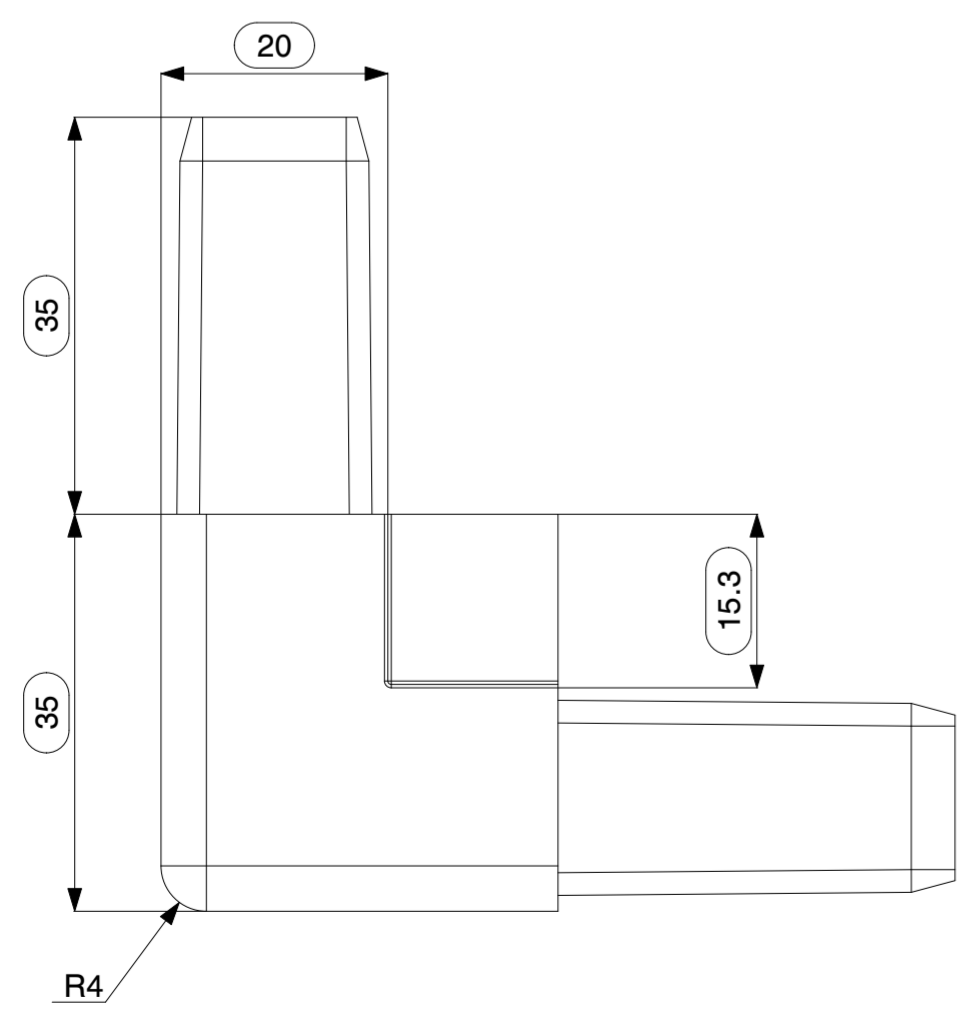
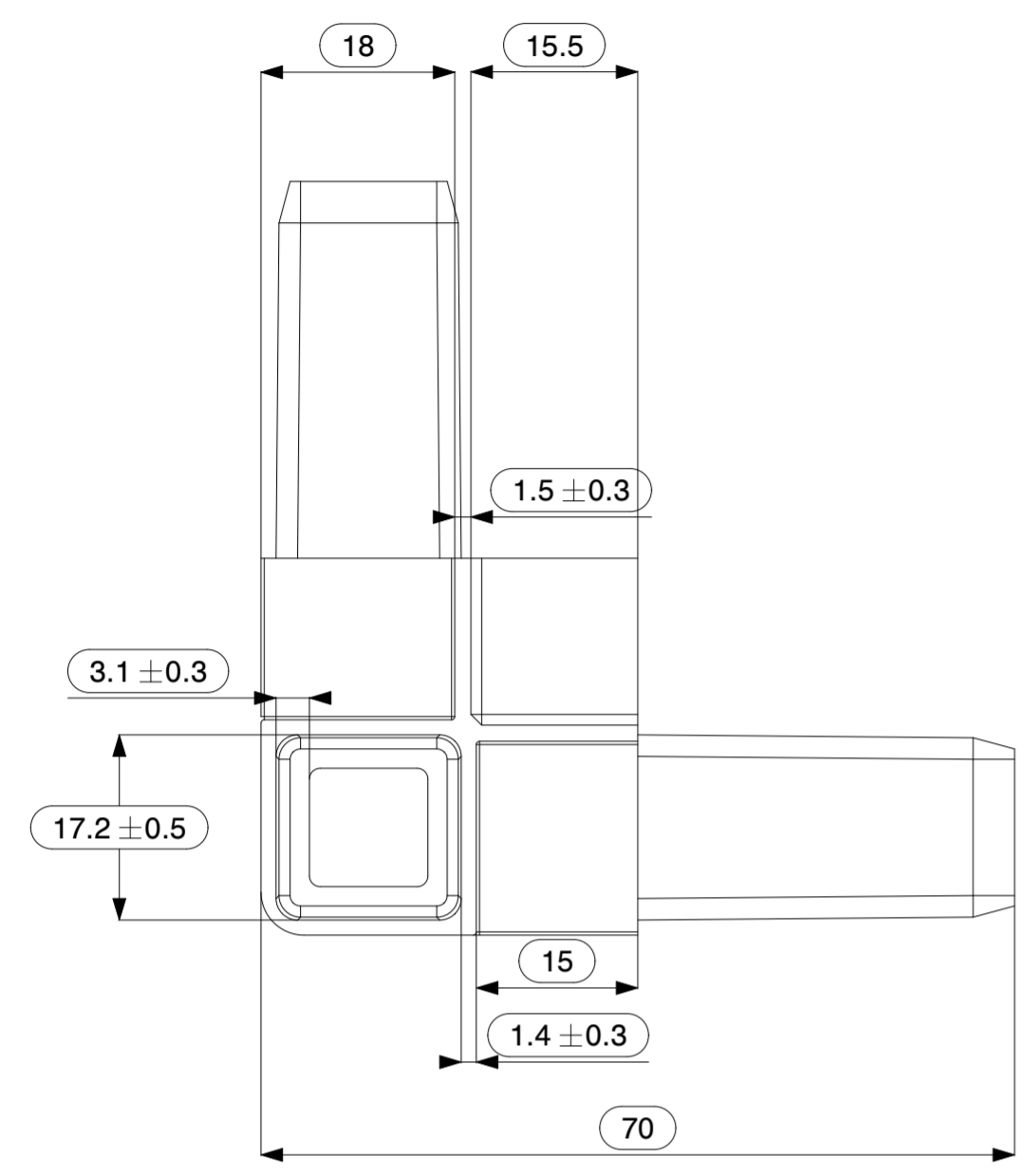

TOLERANCE #		APPROVALS		DATE
0.5 - < 11	± 0.30	DRAWN	VISWA	25-10-2023
11 - < 51	± 0.50	CHECKED	KALEEL	20-01-2026
51 - < 80	± 0.70	APPROVED		
80 - < 120	± 1.00	MATERIAL: PA6 GF 30%		
> 120	± 1.20	WEIGHT RANGE : 38 - 58 grams		
-	-	COLOUR : BLACK		
-	-	THIRD ANGLE PROJECTION		
-	-			
-	-			
WARPAGE = ± 5 mm				
THE MAXIMUM ALLOWABLE DEVIATION FOR ANY ANGLE IS ± 2°		ALL DIMENSIONS ARE IN mm (MILLIMETERS)		

VIVANT SOLUTIONS
 VIVANT SOLUTIONS PRIVATE LIMITED,
 PLOT NO: 329, SIDCO THIRUMULLAIVOYAL,
 CHENNAI, TAMILNADU, INDIA

TITLE: 3 - WAY NON THERMAL BREAK NYLON CORNER FOR 20-15 SYSTEM
PART NO: NTBNYC-20-15
FINISH : SHOT BLASTING

SIZE : A2	SCALE : 1:1	REV : 0
-----------	-------------	---------

REFERENCE STANDARDS : ISO 286 - IT 13